

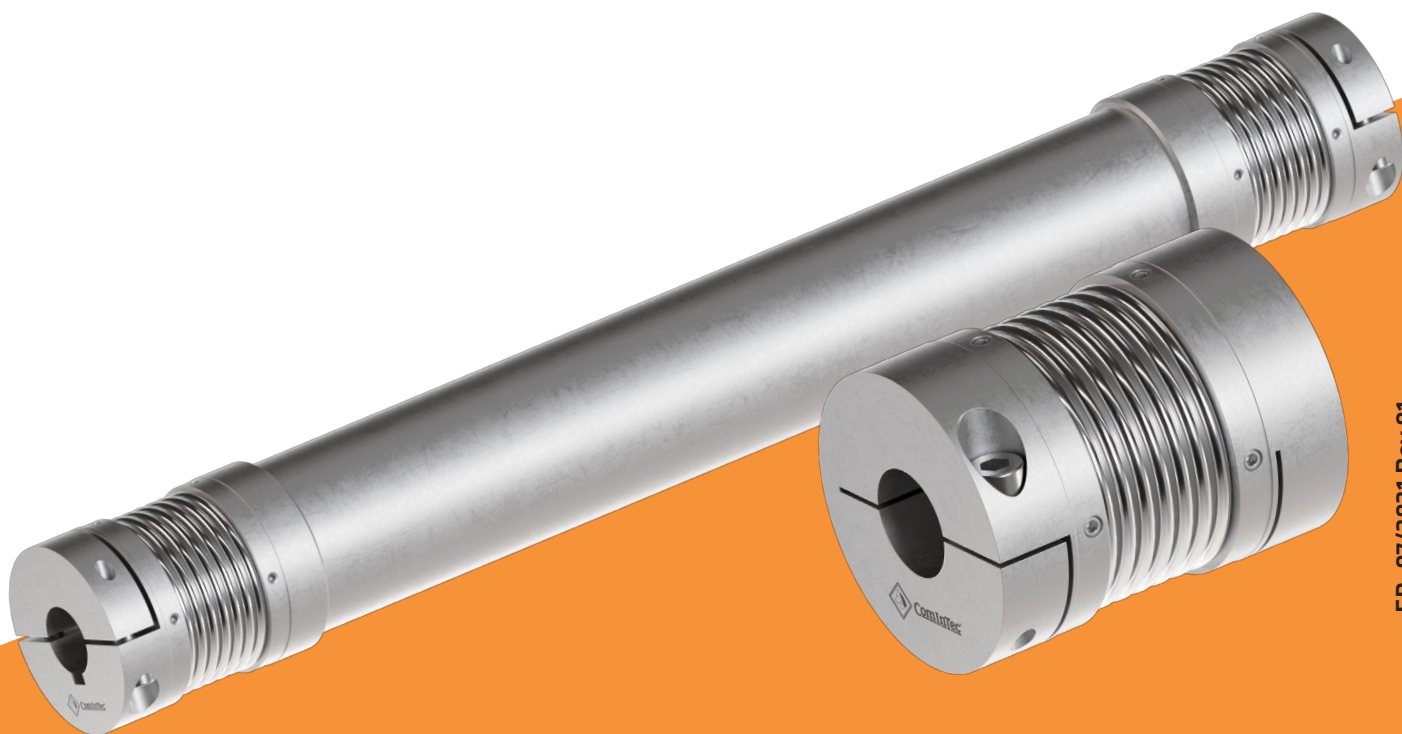

ComInTec[®]
Safety in Power Transmission

BELLOW COUPLING

up to 300 Nm and 45 mm bore diameters



ED. 07/2021 Rev.01



- Download catalog
- Download instruction sheets
- Download 3D and 2D cad model

GSF

GSF - bellow coupling: introduction



- Hubs made in aluminum fully turned and bellow in stainless steel.
- Suitable for applications with high temperatures (> 300 °C).
- High torsional rigidity and low inertia.
- Wear and maintenance free.
- Backlash free for precision and high speeds.
- Single split clamp hub (type B) and finished bore in ISO H8 tolerance and low roughness.

ON REQUEST

- Single split clamp hub with bore and keyway (type B1).
- Two piece clamp hub with bore and keyway (type C1) or without keyway (type C).
- Connection to the Torque limiter's (safety coupling) range possible.
- Customised manufacturing for specific requirements.

The GSF bellow couplings have been designed and manufactured for all applications requiring excellent dynamic characteristics, necessary for high speeds, fast reversing and, at the same time, torsional rigidity with low inertia without compromising the high reliability. The coupling is made in three different and modular elements, in order to obtain high flexibility in assembling and availability. The two shafts are connected to the bellow exploiting a simple mechanic system, easy and safe, by properly sized radial screws and without using bonding agents. In this way the coupling is able to operate and withstand high temperatures, up to 300 °C. The coupling allows the compensation of all possible misalignments between the two shafts, to be connected in accordance to the values indicated in the table, assuring an infinite number of working cycles.

DIMENSIONING

The coupling's nominal torque must be higher than the maximum torque of the motor shaft, according to the generic formula on page 4. For further checks it is useful to verify: inertia on acceleration / deceleration, incorrect positioning in case of application when high precision is required, the natural frequency of the application (simplified system with two masses) according to formulas:

$$C_{nom} = C_{ad} \cdot K \cdot \frac{J_{uti}}{J_{mot} + J_{uti}}$$

$$\beta = \frac{180 \cdot C_{mot}}{\pi \cdot R_t}$$

$$F_e = \frac{1}{\pi} \sqrt{R_t \cdot \frac{J_{uti} + J_{mot}}{J_{uti} \cdot J_{mot}}} > 2 \cdot f_{mot}$$



Where:

C_{nom} = nominal torque of the coupling [Nm]
 C_{ad} = max value between acceleration torque on the motor side and deceleration torque on the user side [Nm]
 C_{mot} = maximum torque on the motor side [Nm]
 F_e = system frequency with two masses [Hz]
 f_{mot} = frequency on the motor side [Hz]
 J_{mot} = inertia on the motor side [Kgm²]
 J_{uti} = inertia on the user side [Kgm²]
 K = load factor
 R_t = torsional rigidity of the coupling [Nm/rad]
 β = rotation angle [°]

Load factor (K)

1,5 = continuous load
 2 = discontinuous load
 2÷3 = machine tools
 2,5÷4 = shock load

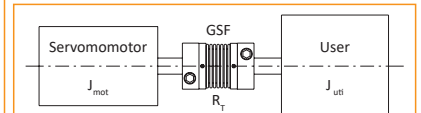

Simplified system with two masses.

FITTING

It is advised to machine the connection's shafts with:

- Surface finish with Ra=1.6 µm.
- Coaxial precision 0.01 mm.
- Nominal tolerance h6.

At first, assemble the coupling by inserting the bellow into the relevant hubs and tighten the screws "S2" in sequence, respecting a cross sequence, continuously until you obtain the tightening torque indicated in the catalogue. Insert one hub on the first shaft along the N length and tighten the clamp locking screw "S1" with a torque wrench, respecting the tightening torque indicated on the catalogue. Leave the second shaft slides on the opposite hub along the whole N length and tighten the clamp locking screw with a torque wrench, respecting the tightening torque indicated on the catalogue.

It is important to consider that misalignments, axial, angular and parallel, must be considered paired together, as inversely proportional (one reduces when the other increases). If all types of misalignments occur, it is necessary that the sum in percentage respect to the maximum value doesn't exceed 100%. If the metallic bellow is damaged, the whole coupling becomes unusable, so it is advised to be very careful in assembling and disassembling the individual components.

GSF - bellow couplings: technical data

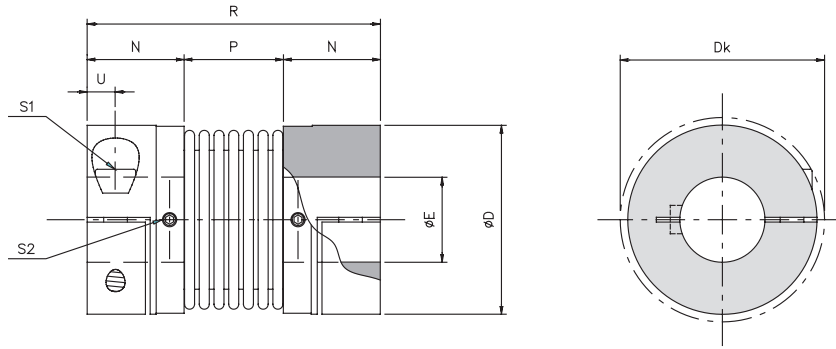

DIMENSIONS

Size	D	Dk	E F 7		N	P	R	U
			min	max				
1	34	36	5	16	17	16,5	50,5	5
2	40	44	8	20	20,5	21	62	6
3	55	58	10	30	22,5	27	72	7
4	65	73	14	38	26	32	84	8
5	83	89	14	45	31	41	103	10

TECHNICAL CHARACTERISTICS

Size	Torque [Nm]		Weight [Kg]	Inertia [Kgm ²]	Max speed [Rpm]	Screws S1	Grub screw S2	Tightening torque		Misalignments			Rigidity		
	nom	max						Screw (S1) [Nm]	Grubscrew (S2) [Nm]	Angular α [°]	Axial X [mm]	Radial K [mm]	torsional R_t [10 ³ Nm/Rad]	axial R_a [N/mm]	radial R_r [N/mm]
1	5	10	0,07	0,000014	14000	M4	M3	3	0,8	1° 30'	± 0,5	0,20	3,050	30	92
2	15	30	0,14	0,000032	12000	M5	M3	6	0,8	1° 30'	± 0,6	0,20	7,000	45	129
3	35	70	0,29	0,000136	8500	M6	M4	10,5	2	2°	± 0,8	0,25	16,300	69	160
4	65	130	0,45	0,000302	7000	M8	M4	25	2	2°	± 0,8	0,25	33,000	74	227
5	150	300	0,93	0,001049	5500	M10	M5	49	3,8	2°	± 1,0	0,30	64,100	87	480

TRANSMISSIBLE TORQUE WITH HUB CONNECTION TYPE B

Size	Torque transmitted [Nm] according to the ϕ finished bore [mm]																							
	5	6	7	8	9	10	11	12	14	15	16	18	19	20	24	25	28	30	32	35	38	40	42	45
1	5	6	7	8	9	10	11	12	14	15	16													
2				13	14	16	18	19	22	24	25	29	30	32										
3						24	25	27	32	34	36	41	43	45	54	57	63	68						
4									58	62	67	75	79	83	100	104	116	124	133	145	158			
5									97	102	107	119	125	132	158	165	183	198	211	231	248	263	277	295

APPLICATION EXAMPLE

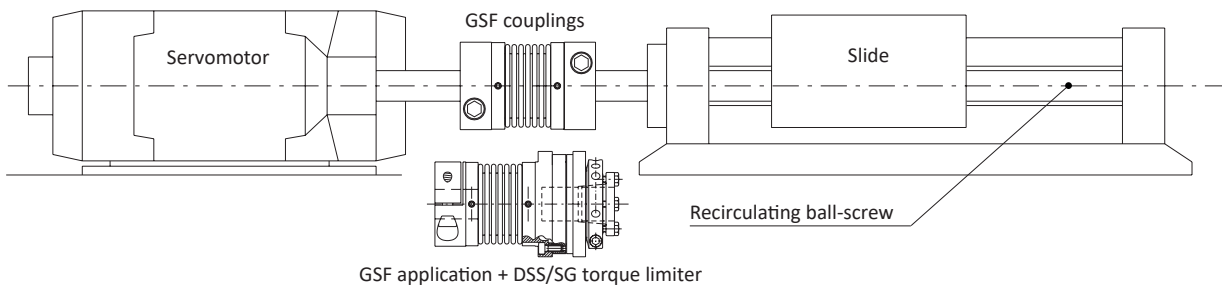

NOTES

On request

- Product available only with finished bore.
- the weights refer to the coupling with minimum bore; inertias refer to the coupling with maximum bore.
- Choice and availability of different hub connection type see pages 4 and 5.

GSF/DBSE - Torsionally rigid spacer shaft coupling with flexible bellow element



- Hubs made in aluminium fully turned and bellow in stainless steel.
- High torsional rigidity.
- Low inertia.
- Customised spacer for specific DBSE.
- Wear and maintenance free.
- Two piece clamp hub dismantlable (type C) for easy installation.

A RICHIESTA

- Two piece clamp hub dismantlable with keyway (type C1).
- Others types of clamp hub with screw (type B or B1)
- Connection to the Torque Limiter's (safety coupling) range possible.
- Customised manufacturing for specific requirements.

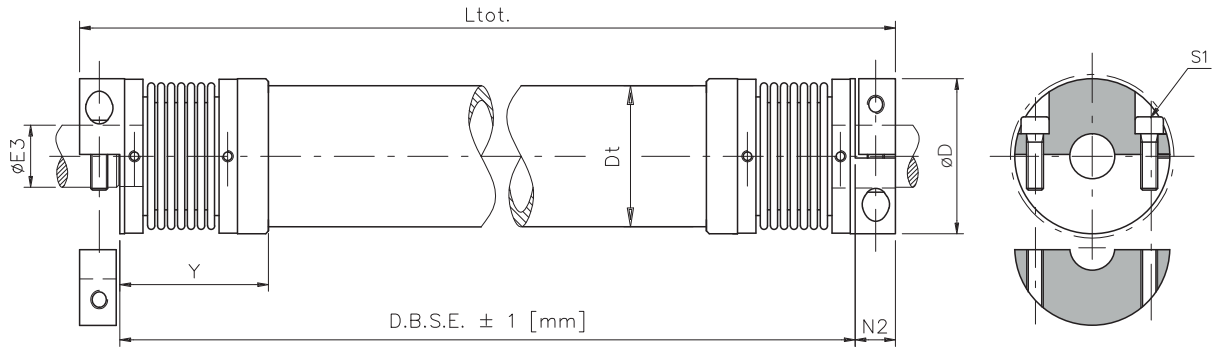

DIMENSION

Size	Torque [Nm]		D	E3 F7		N2	Y	Spacer			Weight tot [Kg]	L _{tot} [mm]	DBSE min [mm]	Rigidity	
	nom	max		min	max			Dt	Weight [Kg/m]	Inertia [10 ³ Kg · m ² /m]				Rigidity R _{r,rel} [10 ³ Nm/rad.m]	Screws S1
1	5	10	34	5	16	10.5	38	30	1,06	0,162	1552	= 2 weight: (GSF) + spacer weight • (DBSE - 2Y) = DBSE + 2N2	96	M4	3
2	15	30	40	8	20	12.5	46	35	1,27	0,273	2650		126	M5	6
3	35	70	55	10	30	14.5	55	50	1,91	0,917	8800		148	M6	10,5
4	65	130	65	14	38	17.5	60	60	3,34	2,184	21150		170	M8	25
5	150	300	83	14	45	20.5	75	70	5,09	4,341	42400		220	M10	49

TRASMISSIBILE TORQUE WITH HUB CONNECTION TYPE C

Size	Torque transmitted [Nm] according to the ø finished bore [mm]																						
	5	6	8	10	11	12	14	15	16	18	19	20	22	24	25	28	30	32	35	38	40	42	45
1	5	6	8	9	10	11	13	14	15														
2			12	15	17	18	21	23	25	28	29	31											
3				20	22	24	28	30	32	36	38	40	44	48	50	57	61						
4							55	59	63	71	75	79	86	94	98	110	118	126	137	149			
5							83	89	95	107	113	119	131	143	149	166	178	190	208	226	238	250	267

ORDER EXAMPLE

BELLOWS COUPLING						
Model	Size	● Bore 1	Hub connection bore 1	● Bore 2	Hub connection bore 2	DBSE
GSF	4	d1=18 F7	B	d2=24 F7	B	-

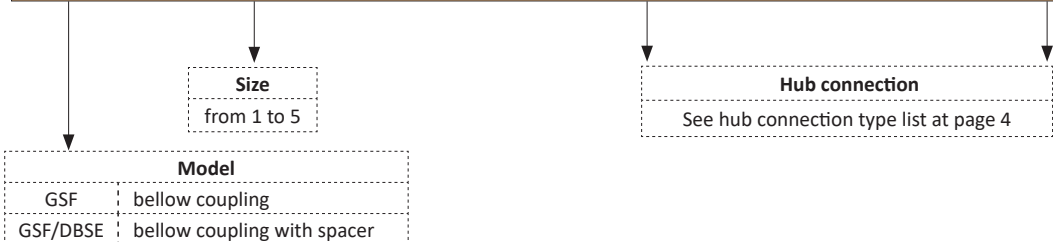

NOTE

- Model available only with finished bore.
- In case of GSF/DBSE model indicate the distance between shaft ends **Example DBSE=250mm**
- The weights refer to the coupling with minimum bore, inertias refer to the coupling with maximum bore.
- Choice and availability of different hub connection type see pages 4 and 5.

In the case of a long DBSE combined with high speed, it may be necessary to use an intermediate shaft with bearing support. Please consult our Technical Department.